

Theory and Art of Evaporative Cooling

Wei FANG

BIME_NTU

weifang@ntu.edu.tw

Evaporative cooling

Poor man's Air conditioning System

Two types

- Pad and Fan System
- Fog and Fan System

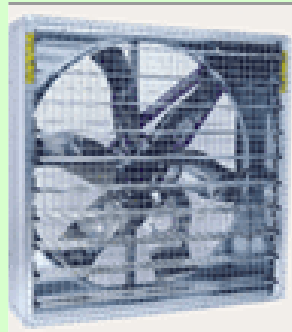

Both suitable for Animal and Plant

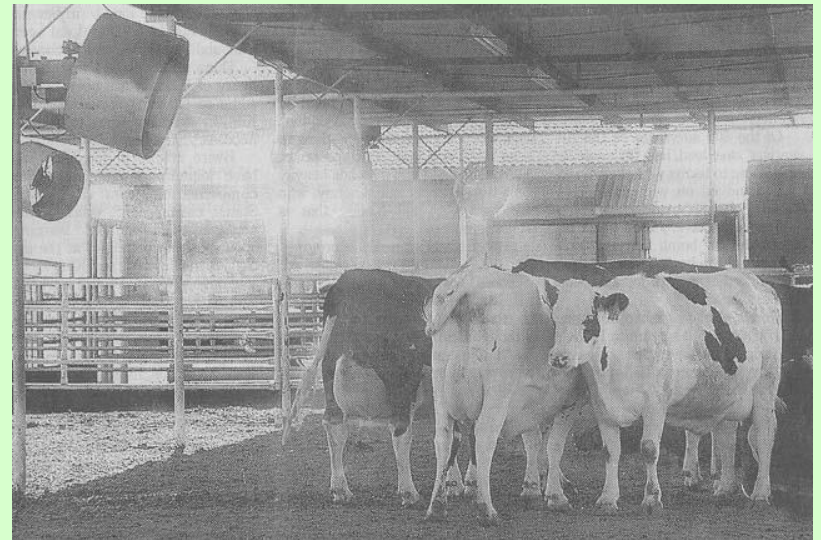

Pad and Fan system is Powerful

But require careful design, install and maintenance.

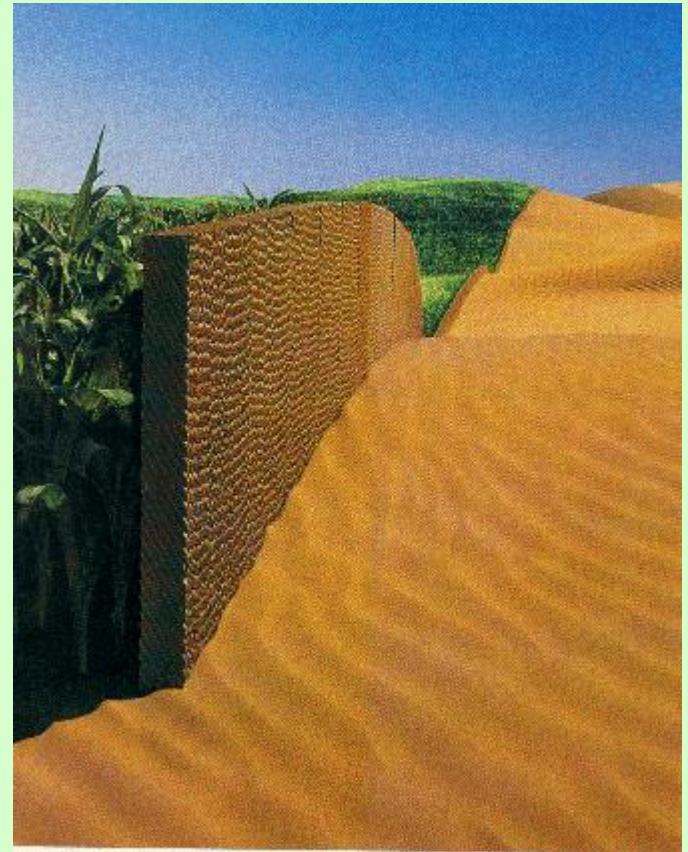

Pad and Fan System

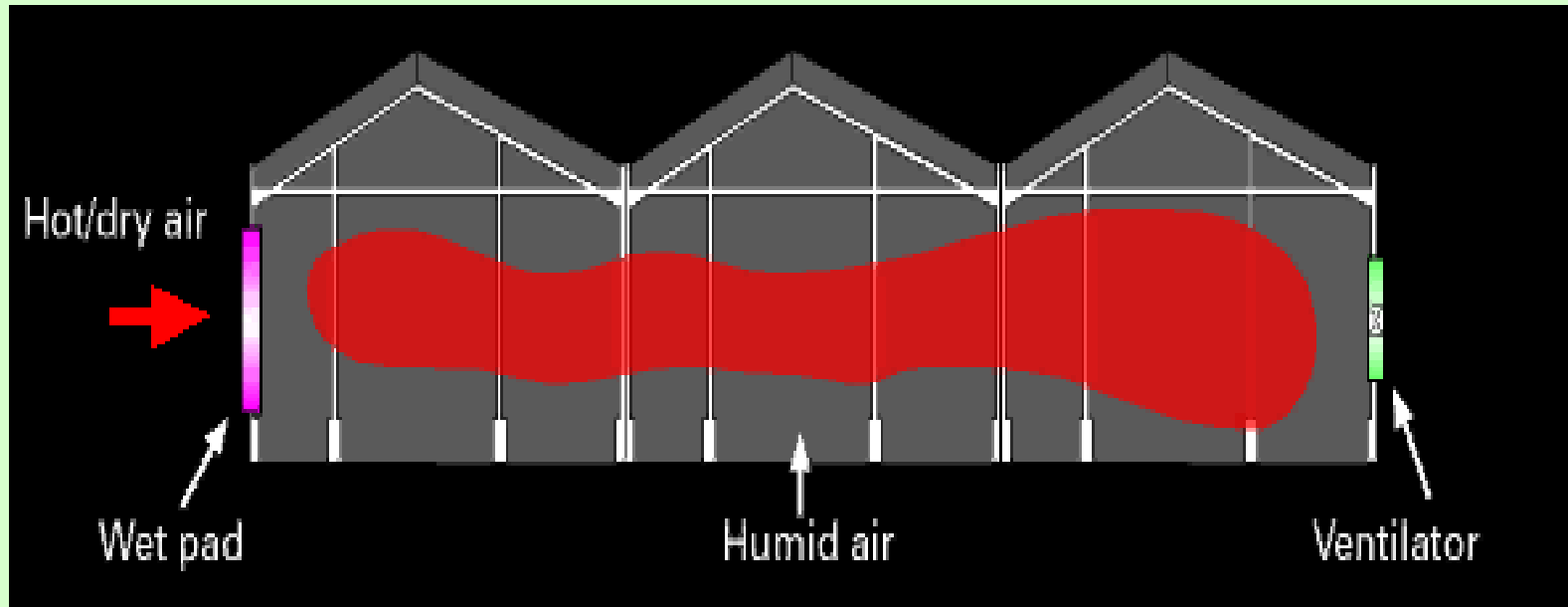

Negative Pressure

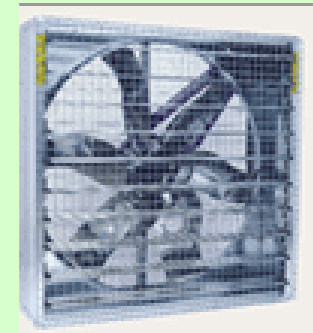

Pad

EKOOLTEC Evaporative Cooling Pads

EKOOLTEC evaporative cooling pads are fabricated from special cellulose material that has been treated with unique ingredients to achieve high cooling efficiency and degradation resistance.

As hot air passes through the evaporative cooling pads a stream of cool and refreshing air is produced.

Ekoooltec 5090 and 7090 evaporative cooling pads are developed to provide exceptional wetting properties and airflow to achieve optimum cooling capacity and maximum durability. Our cooling pads are your best choice!



Applications

Poultry and Livestock industry

Poultry farms
Livestock
Hatcheries
Dairy farms

Greenhouses & Horticulture industry

Vegetable storage
Mushroom farming
Seed farming
Floriculture

Industrial and comfort cooling

Cooling fan
Precoolers
Industrial humidification
Residential cooling



Greenhouse



Poultry house



Pig house



Pig farm



Factory



Evaporative cooler

Greenhouse



Poultry House

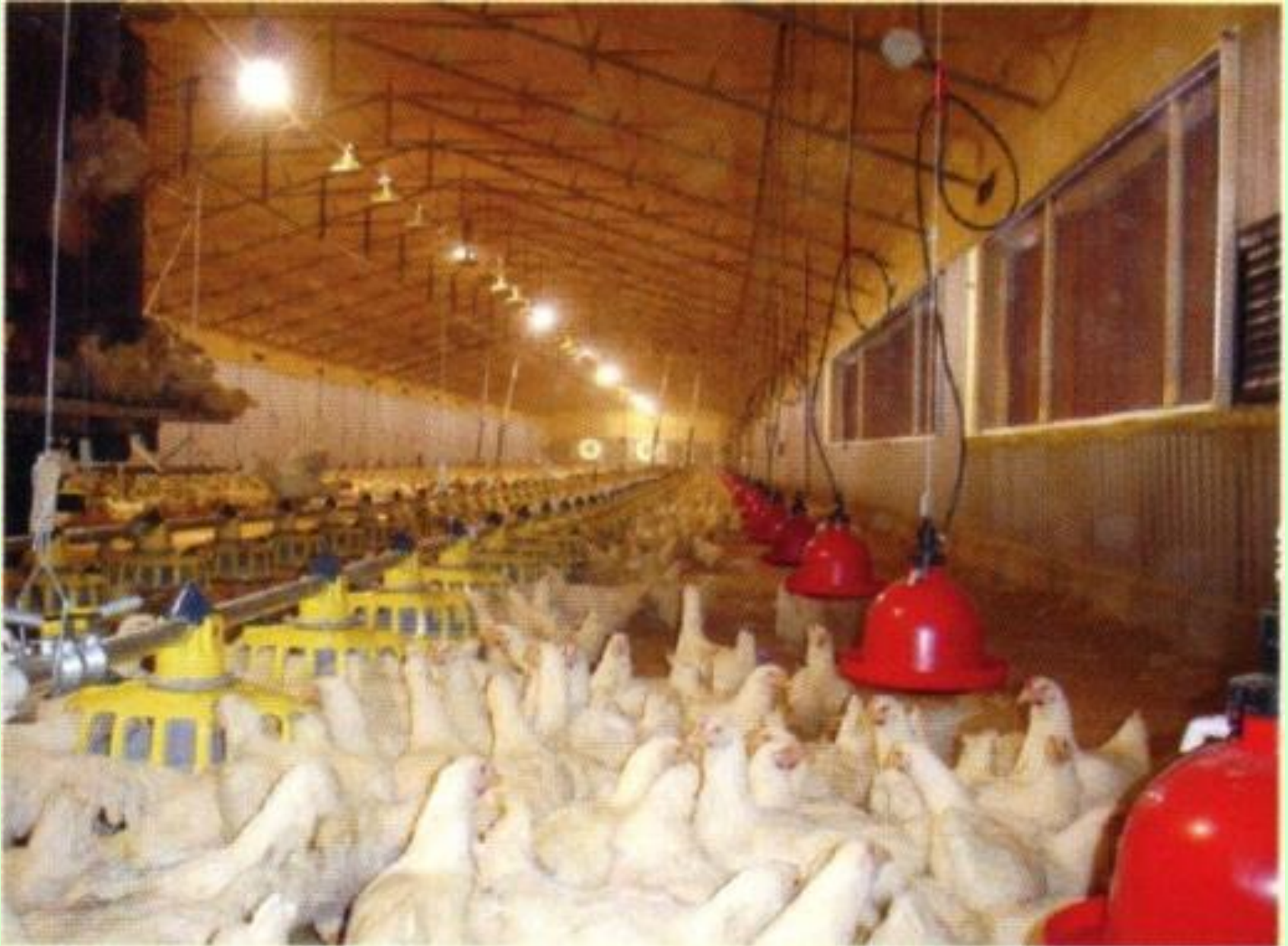

Pig House



Pig Farm



Factory



Unit Device

- Pad and Fan are together in an unit
- Positive pressure system

Evaporative Unit Cooler



Features

- Excellent wetting properties
- High evaporation & cooling efficiency
- Low pressure drop
- Strong and self supporting
- Long life span
- Dirt resistant
- No water carry-over
- Self cleaning
- Low operating cost
- ECO friendly
- Easy to install

Install Sketch Map

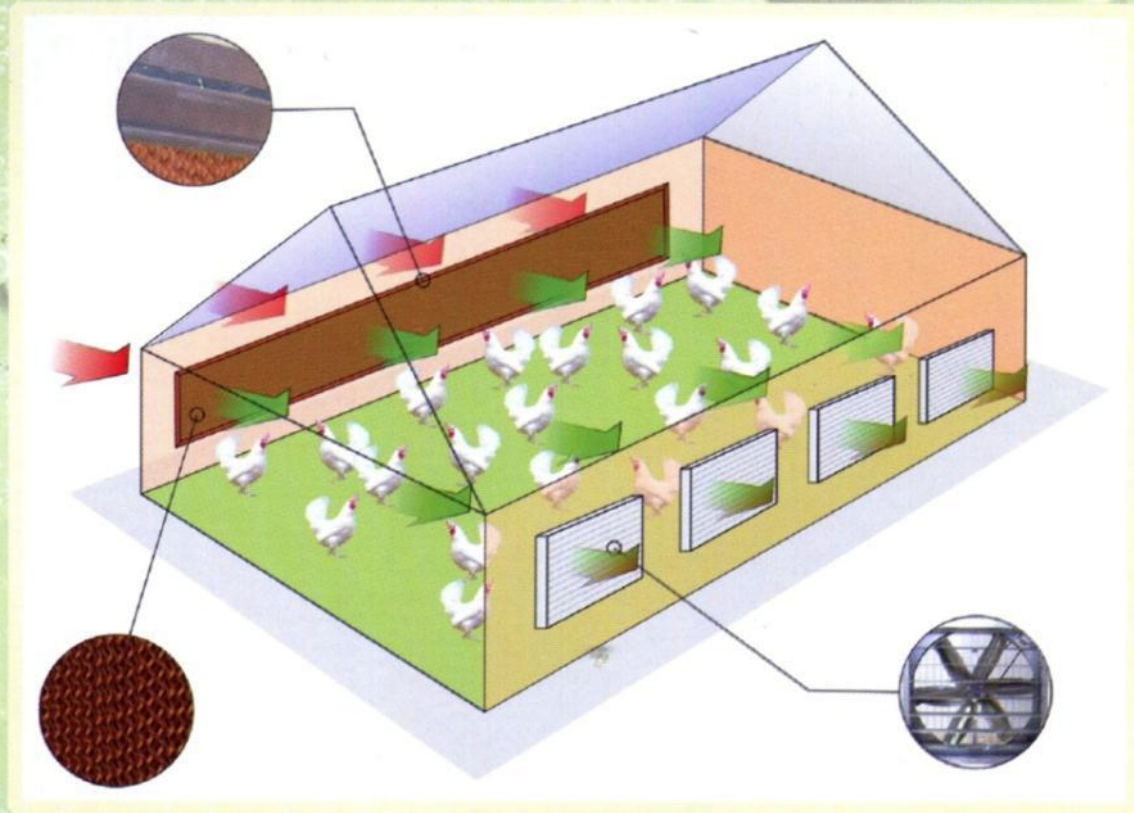

Key factors

- Outdoor WBD: wet bulb depression
- Efficiency
- Pressure drop
- Air tightness
- Air Flow

Efficiency

$$WBD = T_{db} - T_{wb}$$

Dry bulb – Wet bulb

T_{db}

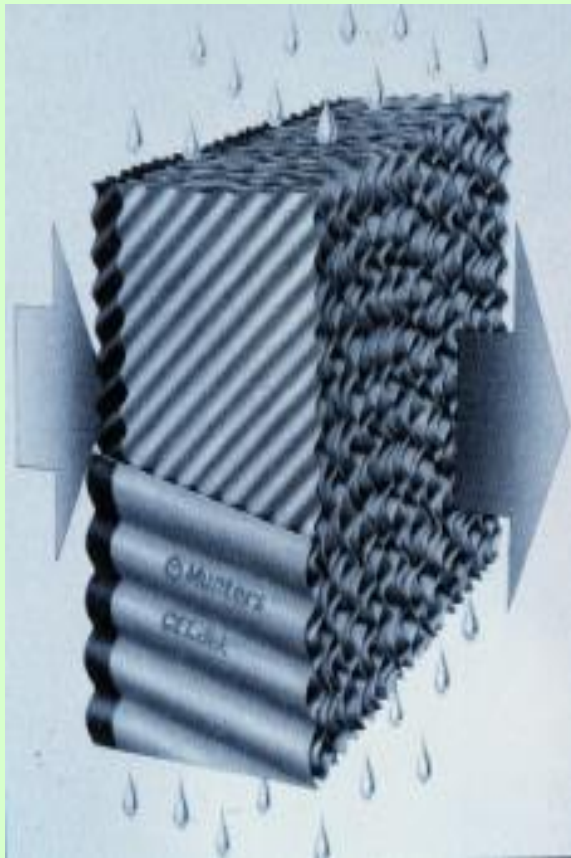

$T_{db} - \Delta T$

$$\eta = \Delta T / WBD$$

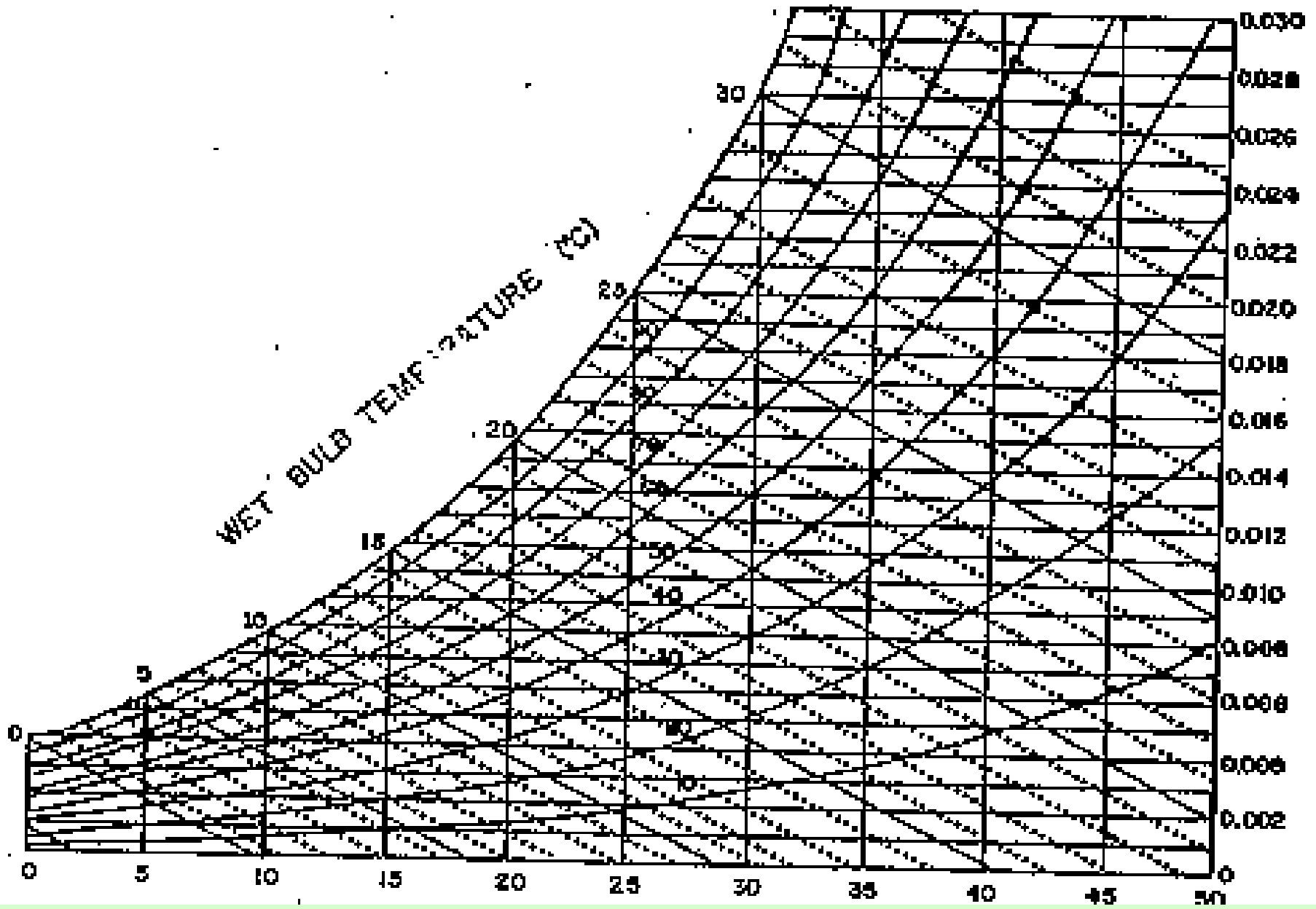

Saturation efficiency CELdek 7060-15

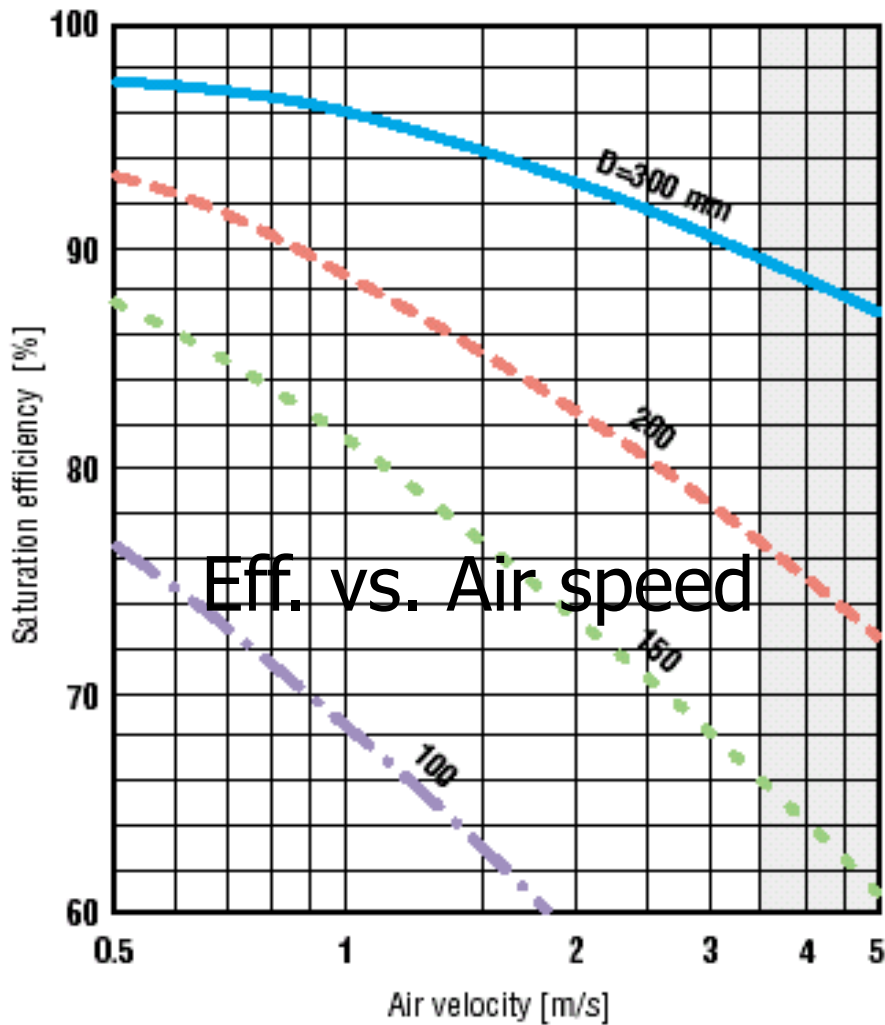

- D=300 mm
 - - - D=200 mm
 - · · D=150 mm
 - · - · D=100 mm
- Risk of droplet (grey field)

Pressure drop CELdek 7060-15

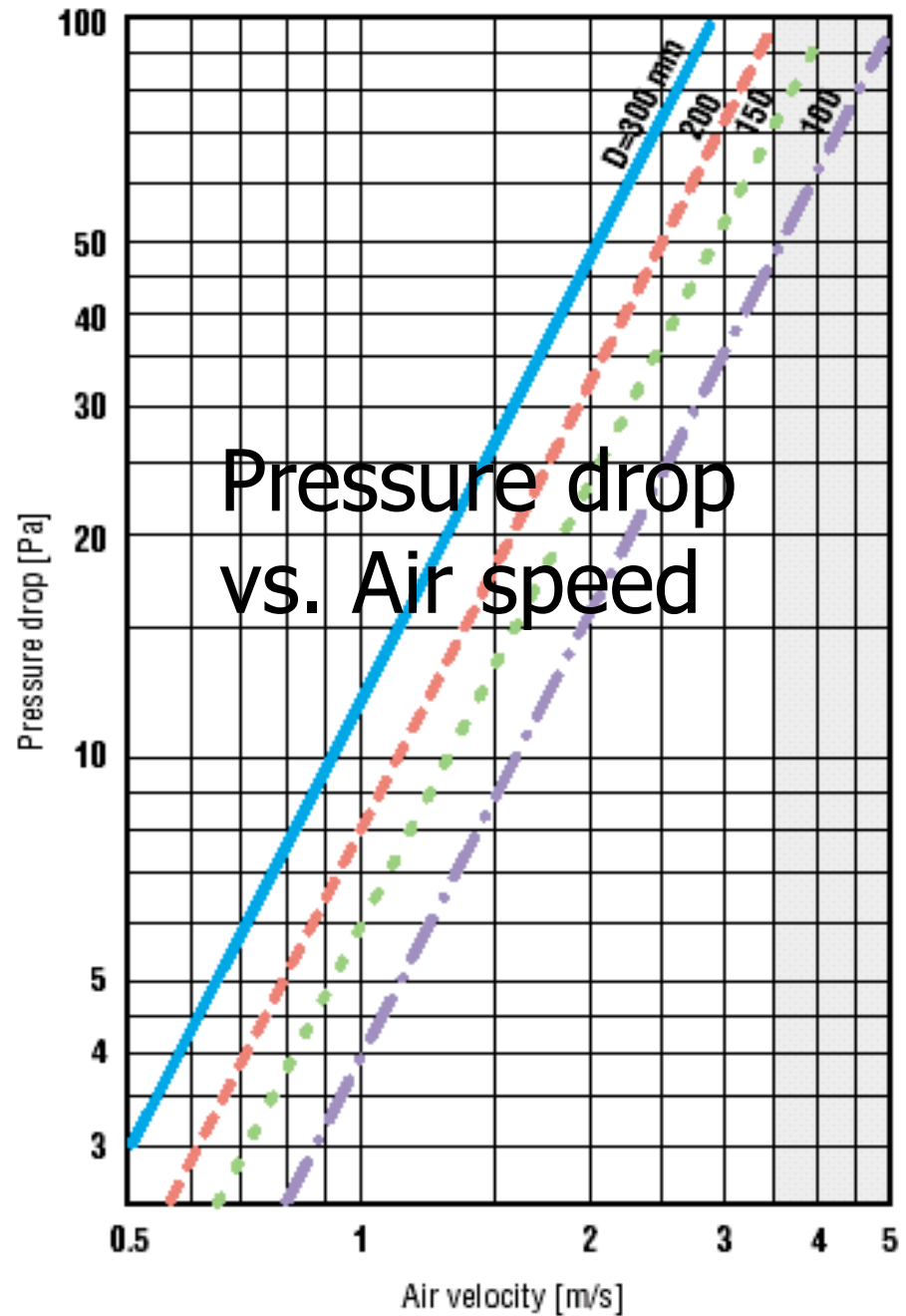

Flute Angle: 7060

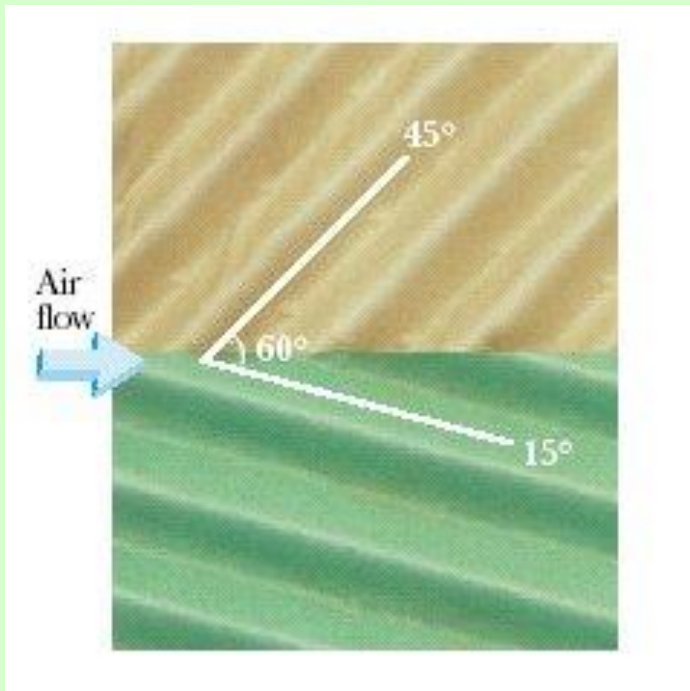

Flute Angle: 7090

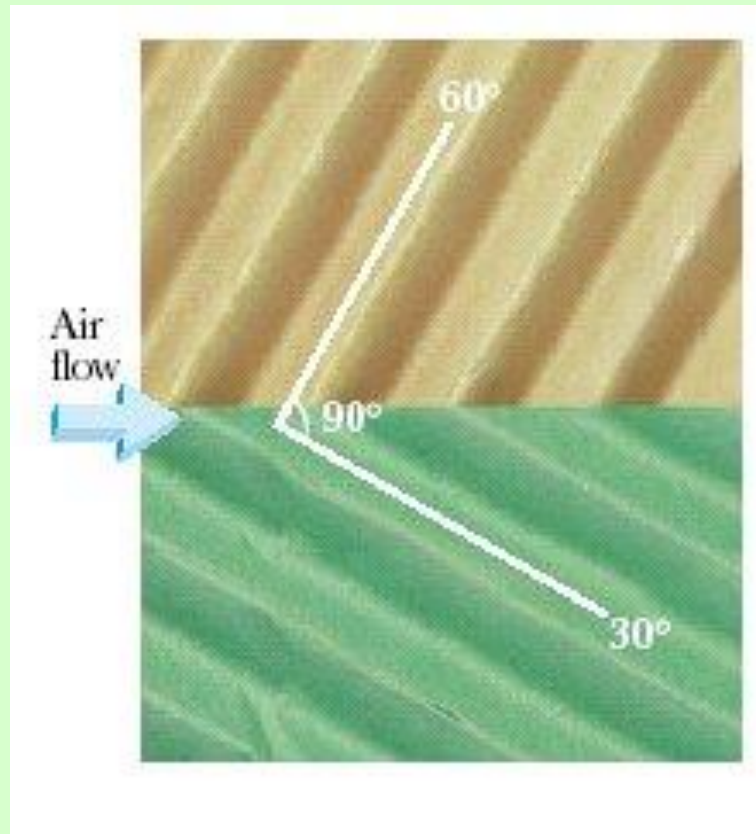

水簾片之編碼 h0xx (xx = a + b)

Model & Parameter

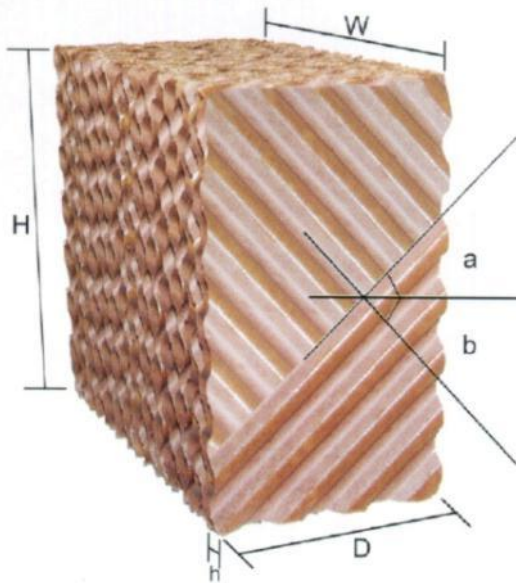

	7090	5090
H(mm)	1500,1800,2000	As per requirement
W(mm)	900,600	As per requirement
D(mm)	100,150,200,300	50-150
h(mm)	7	5
a(°)	45	45
b(°)	45	45

H: Screen Height W: Screen Width h: Flute Height
D: Screen Depth a: Grove Angle b: Grove Angle

Ekooltec 5090 水簾片 在不同風速下的效率與壓降

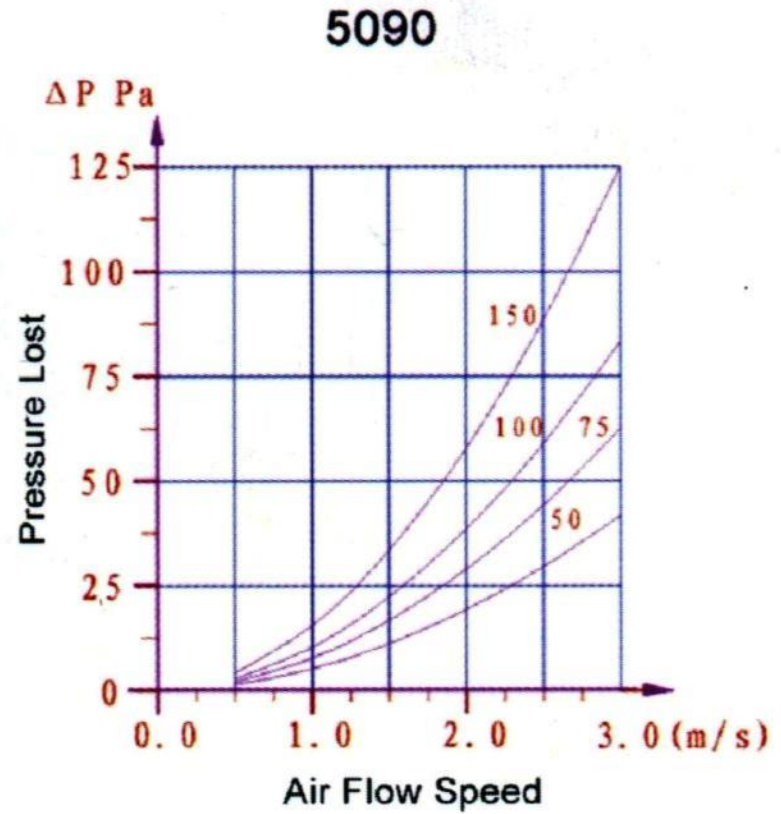
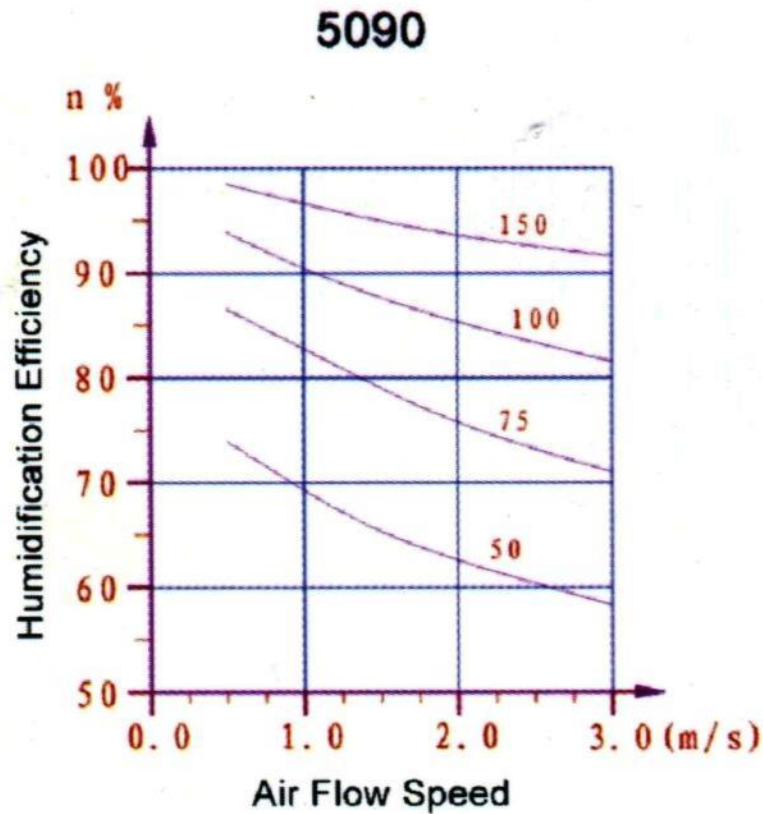

Ekooltec 7090 水簾片 在不同風速下的效率與壓降

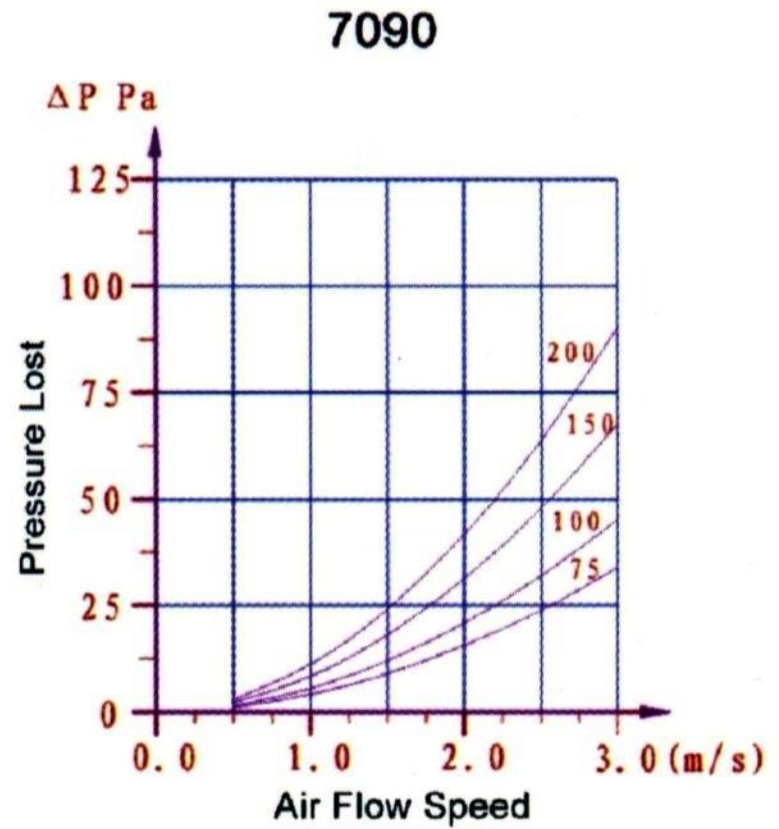
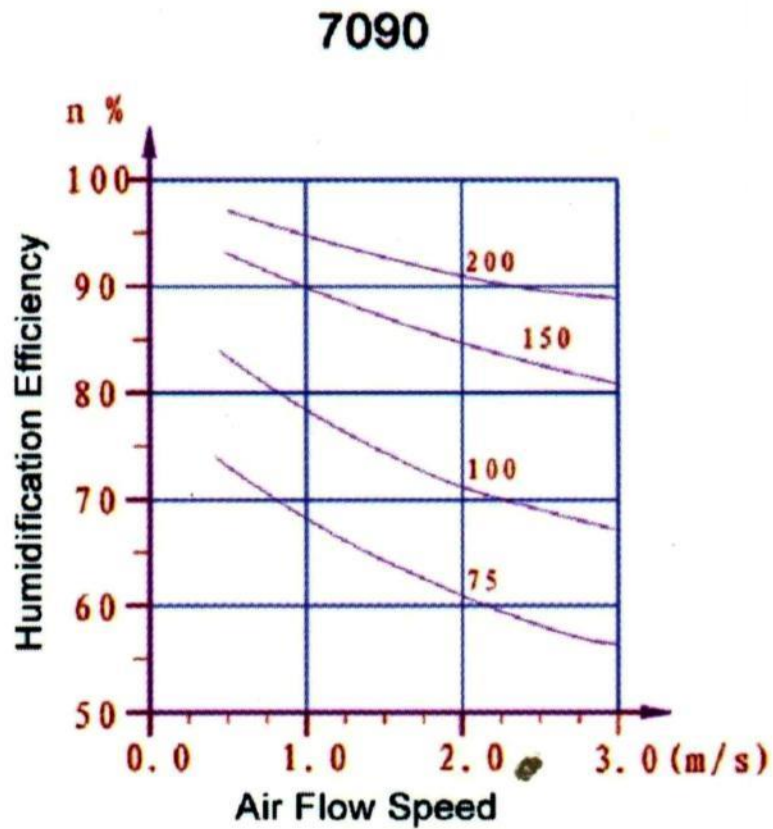

Misleading

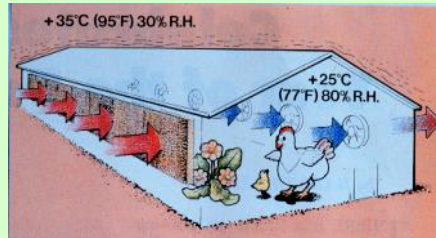

Actual case

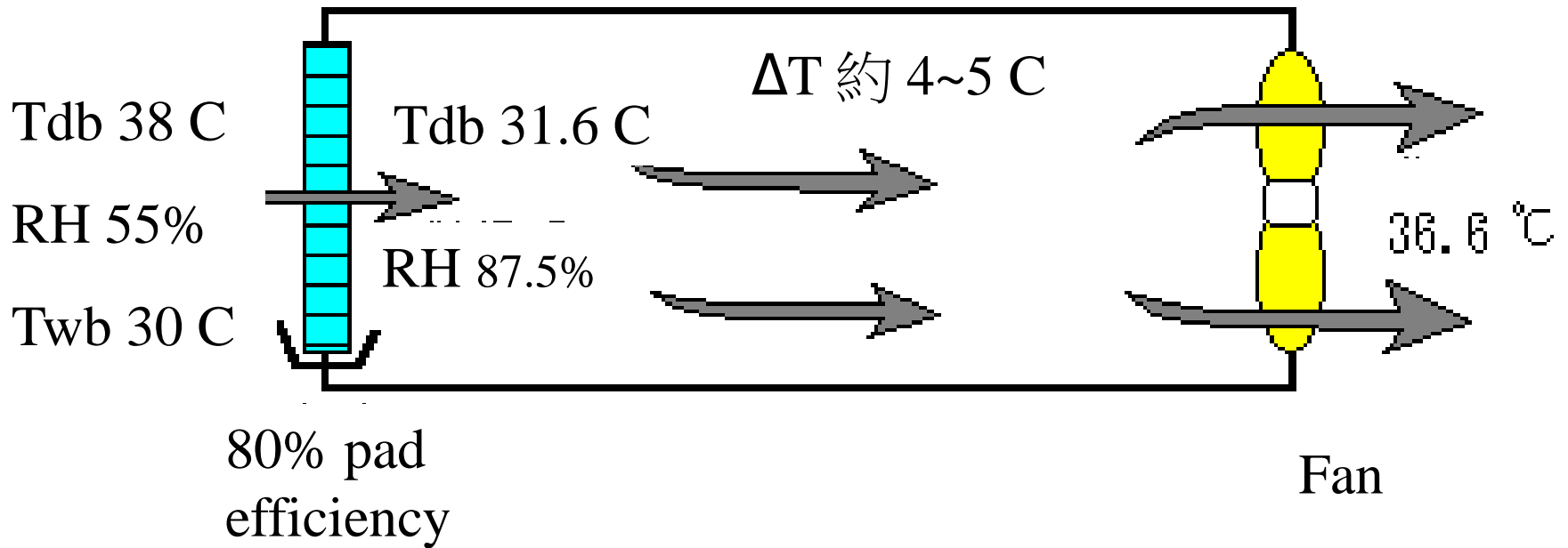

Opening adjusted following air flow

調整方式：外牆，捲簾，百葉

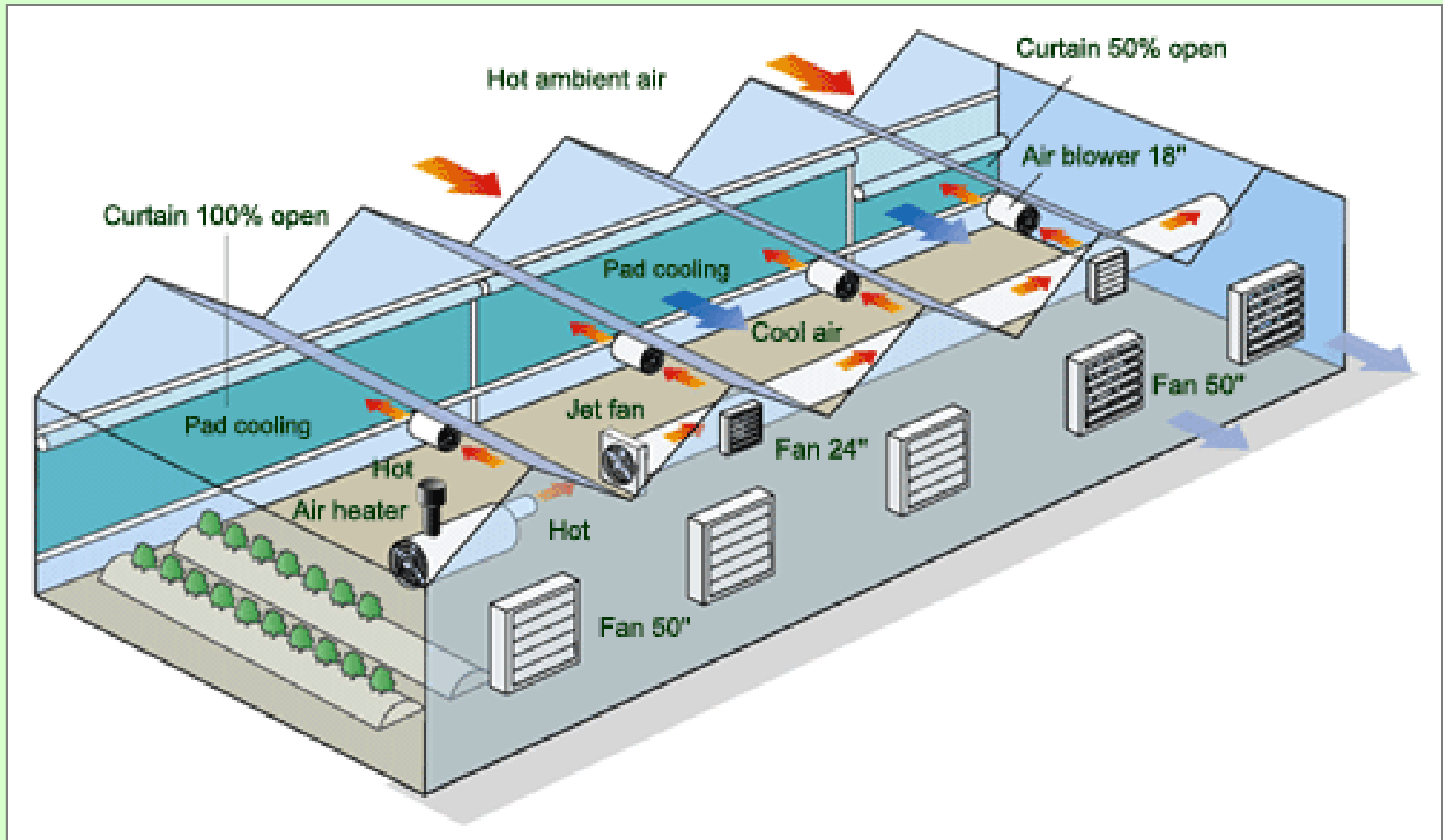

Methods related to Opening Adjustment

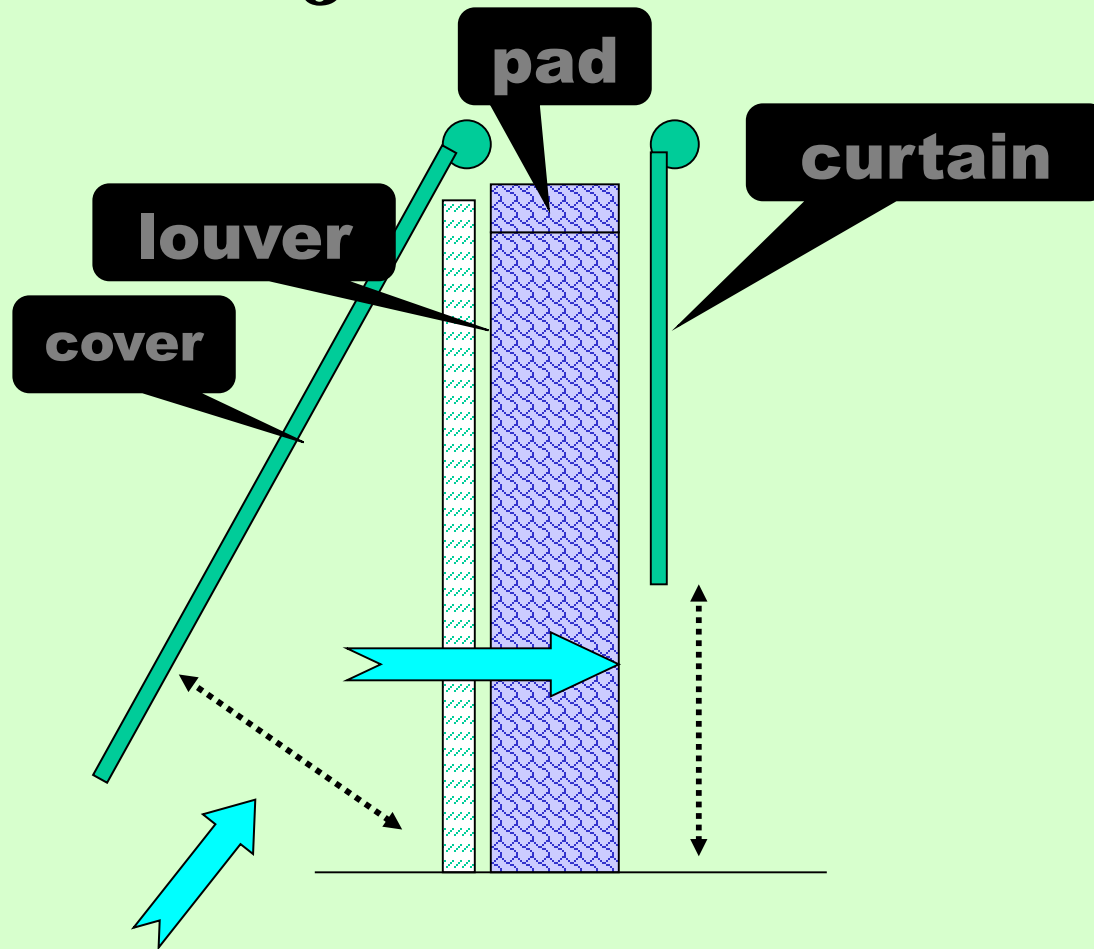



insect nets
wrong

Cheapest way



Bigger net, less pressure drop

Better way to install the nets



Proper way



Louver of the fan



better

Air tightness

poor



Uneven distribution due to block



Poor maintenance or design



Too low



Too close



Too many small fans



Small fan poor VER

VER

$(\text{m}^3\text{Air}/\text{s})/\text{kW}$

$(\text{m}^3\text{Air}/\text{degree})$

Poor design



Poor design

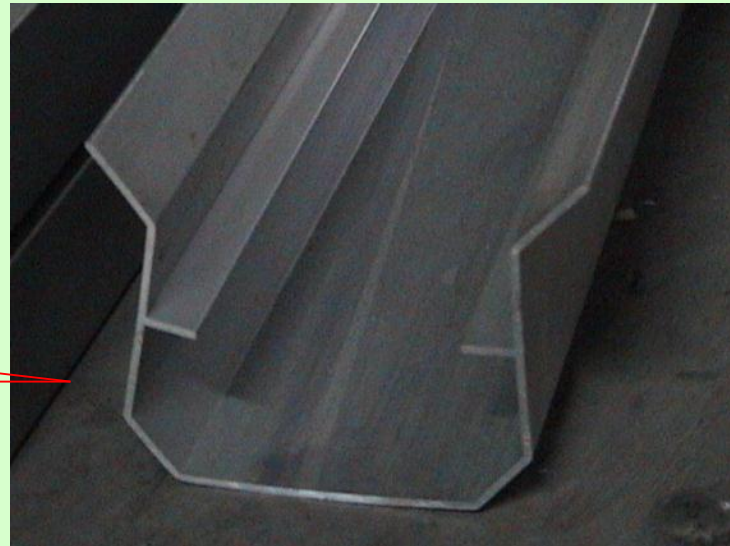
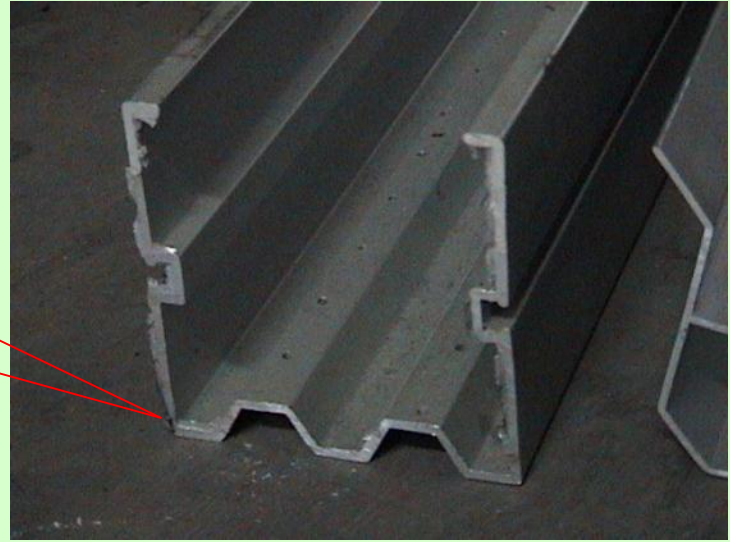
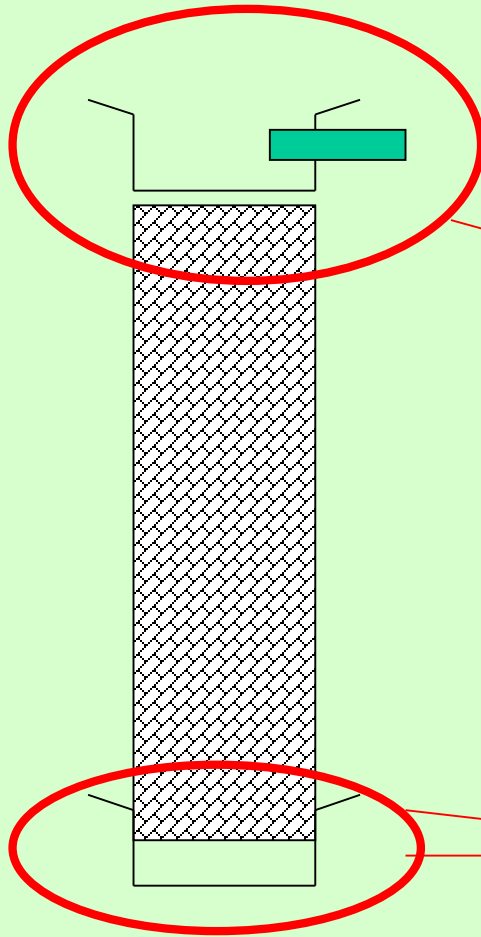

Easy to block/clog



Algae, Accumulative filth



Proper design

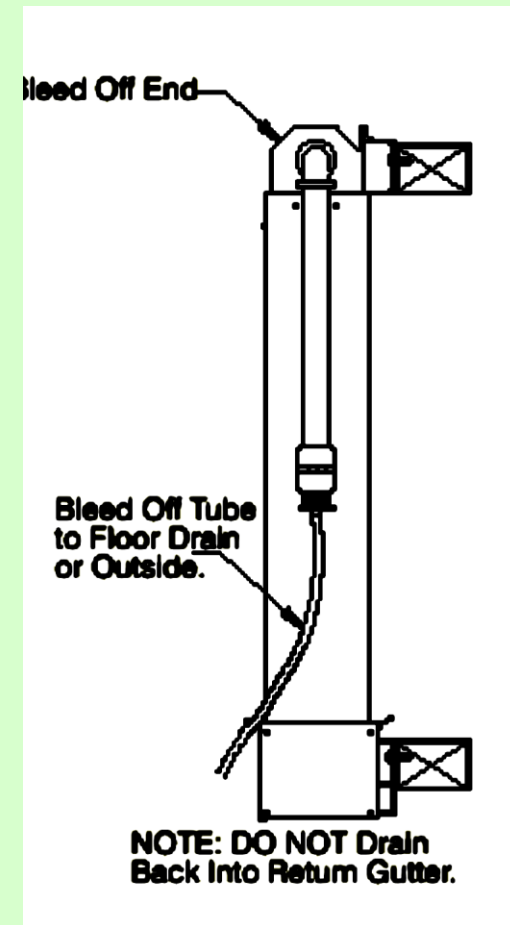
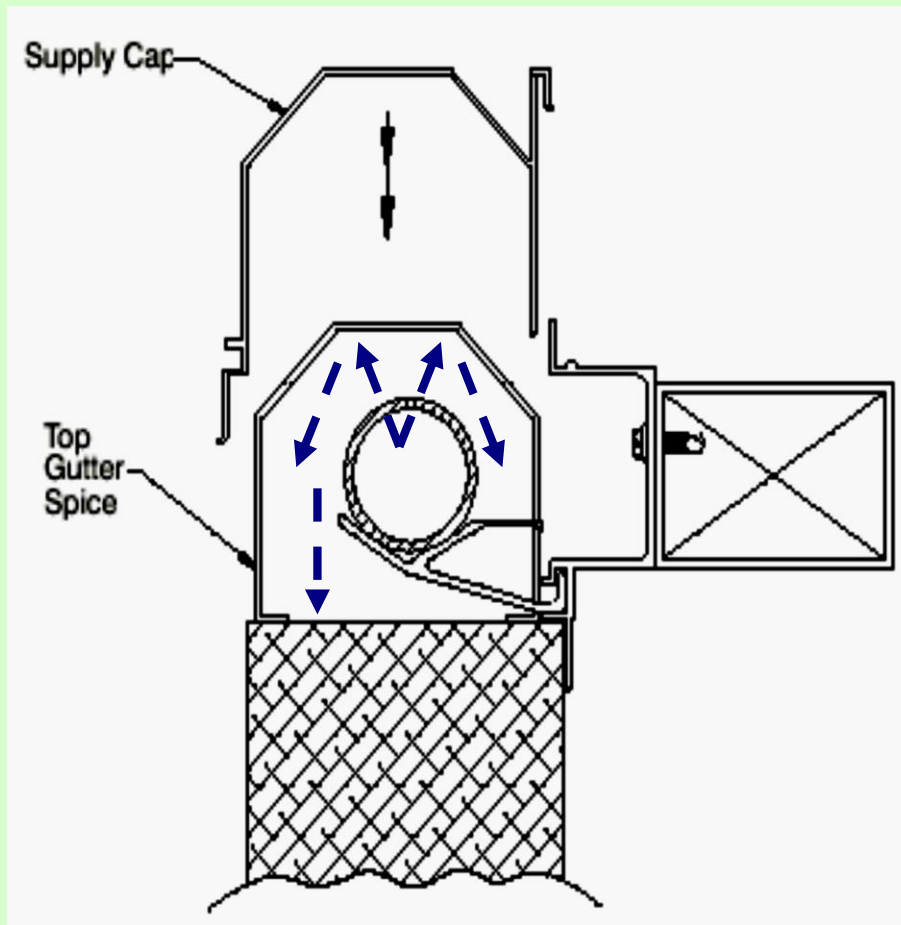



Coated Pad



Pad substitutes - Palm tree fibers



科威特



Pad substitutes – Rolling Nets

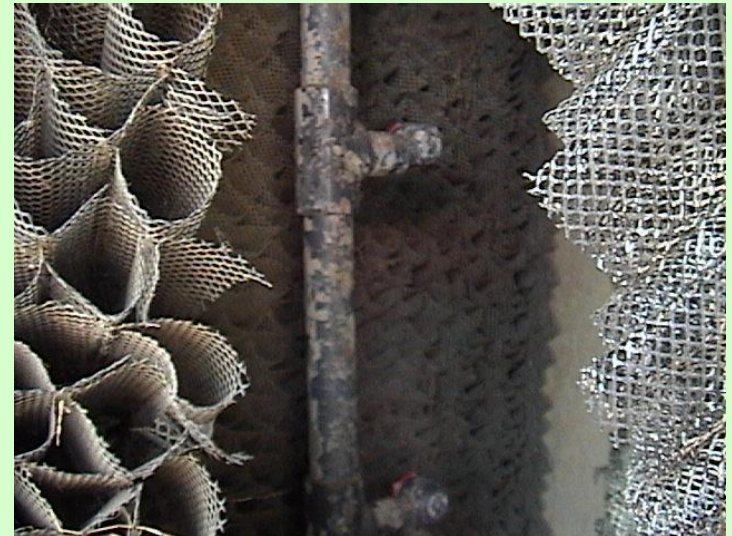
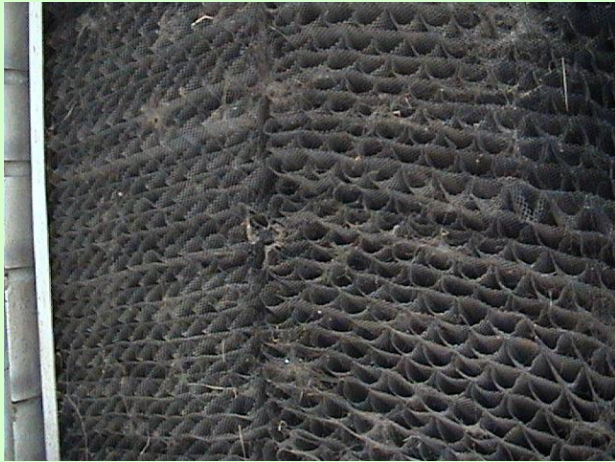

Pad substitutes - Multi-layer Nets



View from outside



View from inside

Fogging is better than spray

Pad substitutes - Multi-layer nets with fogging or misting

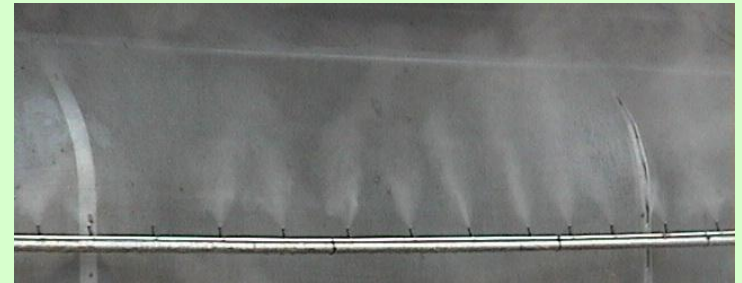
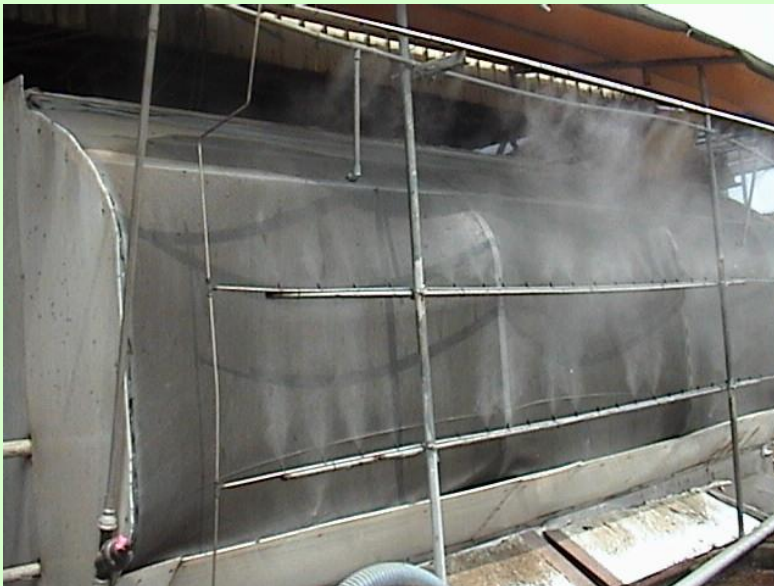

Terminology

Fogging

- Particle size much smaller
- Used for cooling
- Single line system: required high water pressure
- Dual line system: required high air pressure

Misting

- Larger particle size
- Used for
 - spraying chemicals
 - humidification
 - irrigation

Fogging System

- Fogging with high pressure nozzle
 - Pressure @ 1000 psi (68 atm) to create fog
- Evaporative need energy from air
- Soft water is better to prevent clogging of the nozzle
- $RH > 80\%$ stop fogging
- Limit: wet bulb temperature of indoor environment

Multiple Applications of Fogging

- Sprays
 - Humidifying
 - Cooling
- Recreation
 - De-odor
 - Anti-dust

Multiple applications in various industry

公害防治	排氣冷卻、調濕、洗淨、消毒、排水處理、除臭、消泡、廢氣處理、鎮塵	汽車業	塗裝線的加濕、塗裝底漆處理、塗裝線的鎮塵、防漏水試驗、冷卻、洗淨、燃燒、其他
鋼鐵業	冷卻、除鏽、塗裝、鎮塵、排氣處理、排水處理、除臭	農畜業	除蟲、降溫、加濕、除草、洗淨
電子業	塗佈、洗淨、加濕、蝕刻、顯影、剝離	石油業	冷卻、防火、防災、散佈
製紙業	加濕、洗淨、污水處理、除臭、消泡、切邊、散佈、鎮塵	食品業	加濕、冷卻、洗淨、消毒、塗油、促進發酵、污水處理、除臭、消泡、洗桶槽
紡織業	加濕、洗淨、冷卻、消毒、污水處理、延展、散佈、回潮	化學業	冷卻、加濕、散佈、廢氣處理、排水處理、造粒、防火、防災、反應

Multiple applications in various industry (continue)

娛樂業	噴泉、造景、霧狀螢幕、特殊效果	瓦窯業	加濕、冷卻、洗淨、鎮塵、散佈
電鍍塗裝	洗淨、排水處理	玻璃業	靜電的防止、冷卻、洗淨
核電業	冷卻、防災、排水處理、污水處理	醫療業	洗淨、消毒、吸引藥霧化
造船業	洗淨、廢氣冷卻、空調加濕	環境衛生	消毒、除臭、保濕、除塵
木材業	去皮、洗淨、加濕	建築土木	廠房空調加濕、洗淨、塗油、外表洗淨
海水淡化	脫氣、脫二氧化碳	其它	其它各式應用

Indoor Insecticide spraying



Outdoor Insecticide fogging for pest control



Fogging Vehicle of Mr. Lin



Cooling/Humidifying





Dairy barn cooling-1

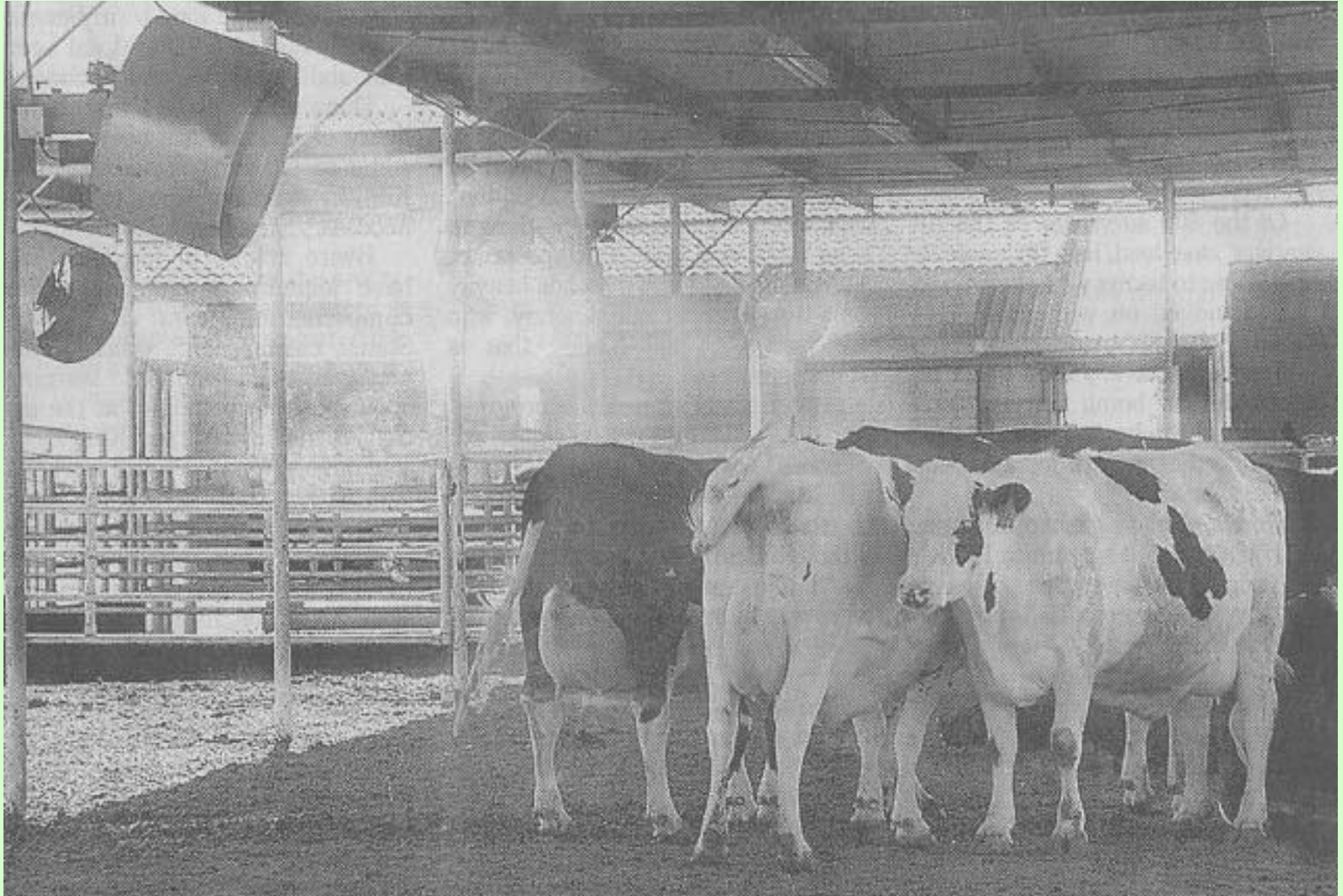

Dairy barn cooling-2



Dairy barn cooling-3

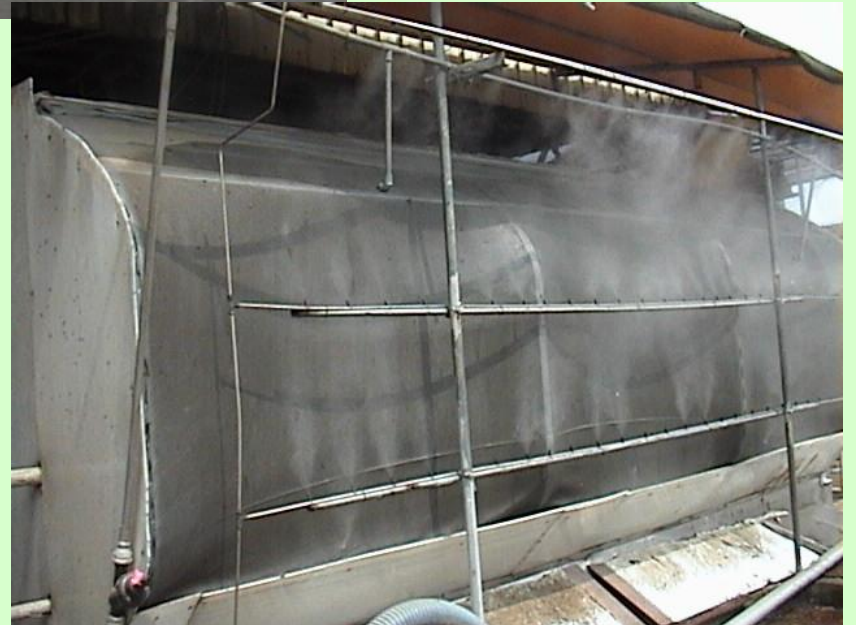
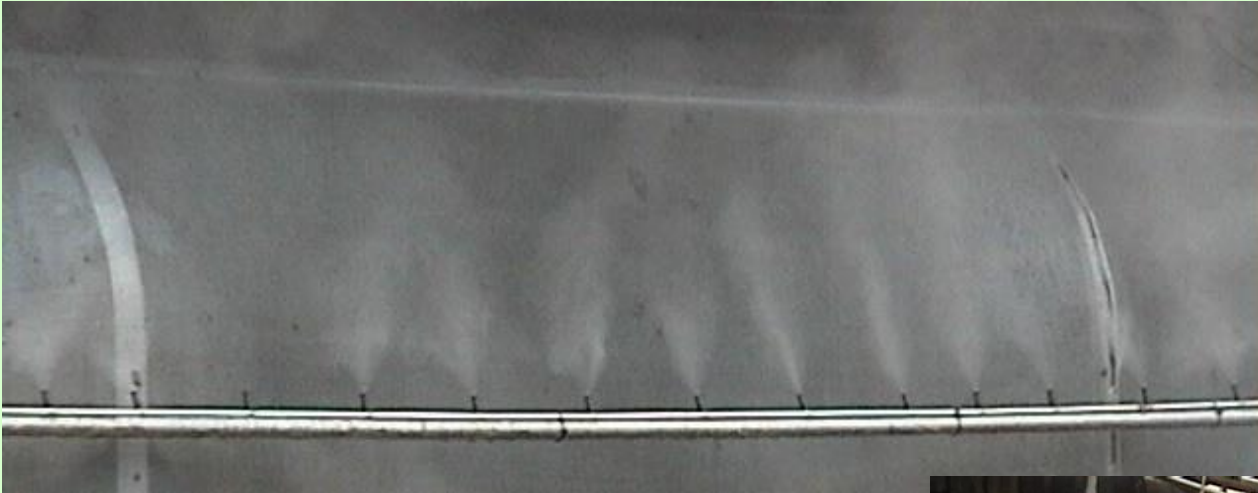

Mushroom house cooling



De-odor outside the pig house



Open field cool zone



Heat treatment cooling



Open space cooling outdoor fun













Anti-Fire



https://youtu.be/tY_okhRlkBI

Cabinet humidifying



Cooling, de-odor, anti-dust



De-odor, Anti-dust



Force dust to drop down



fog generating

nozzle

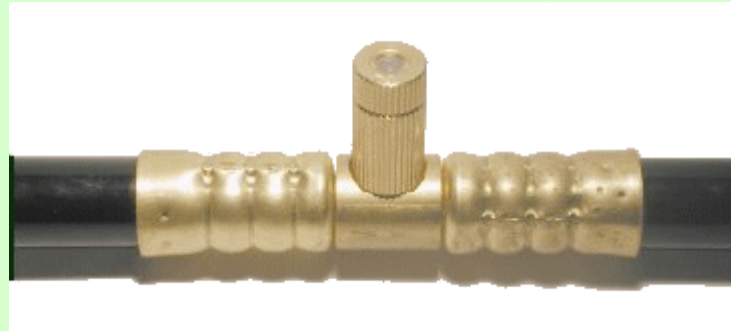



High pressure fogging

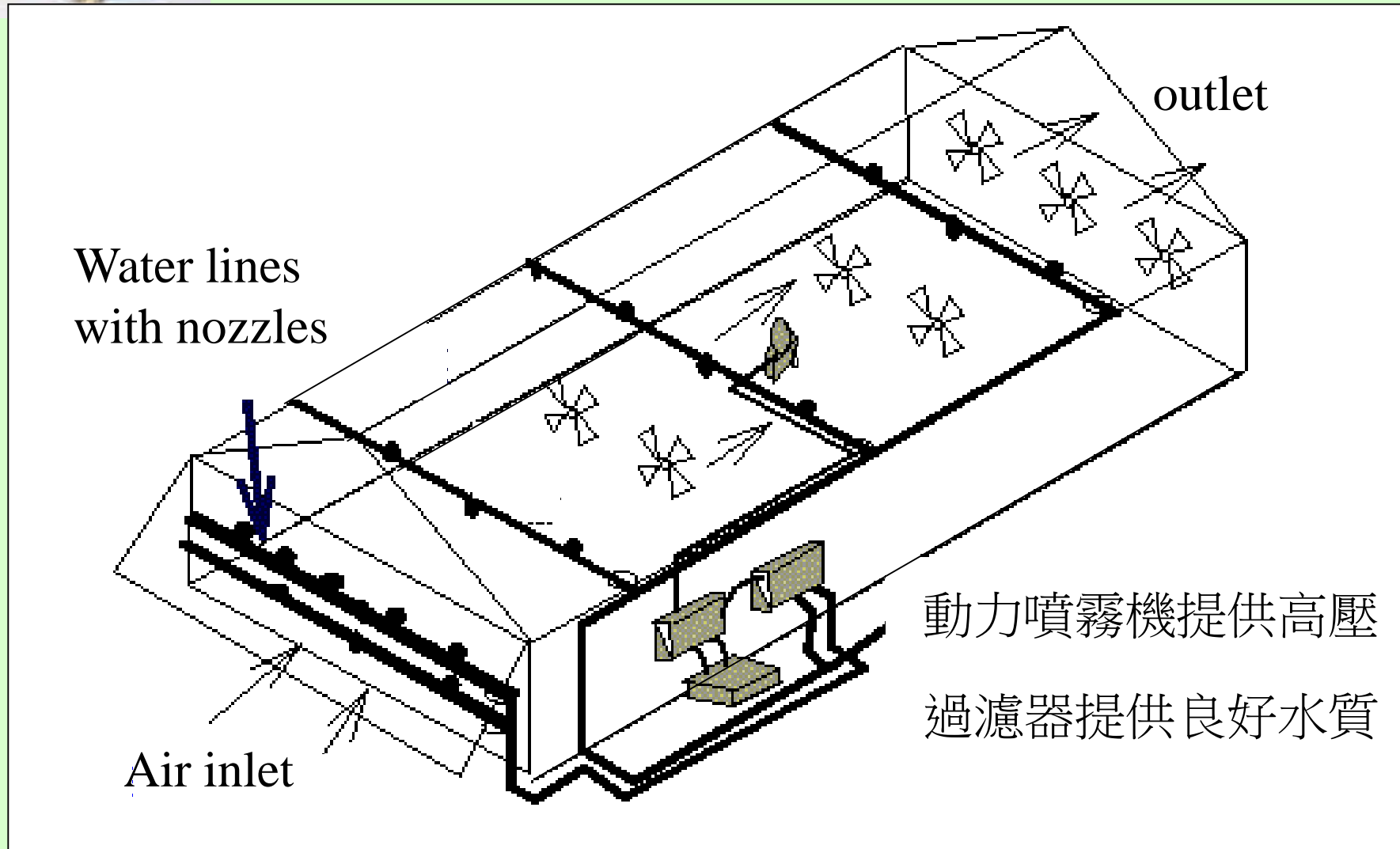

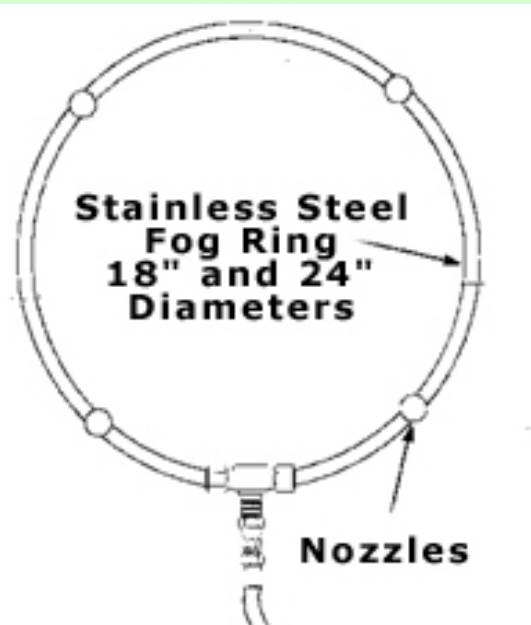



Droplet hit the rotating cup and
break into mist/fog

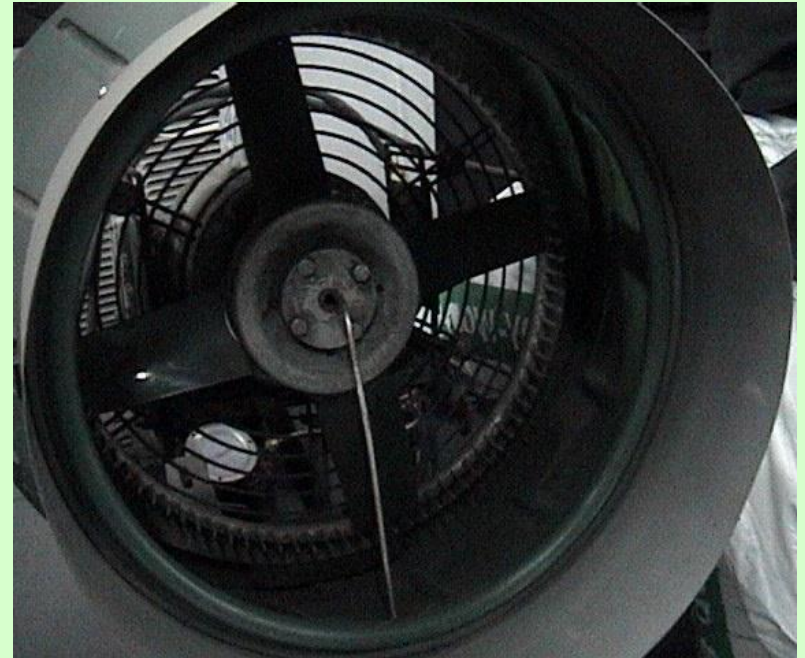

Spinning atomizer



Bi-flow nozzle with air compressor



Ultra-sonic fogging

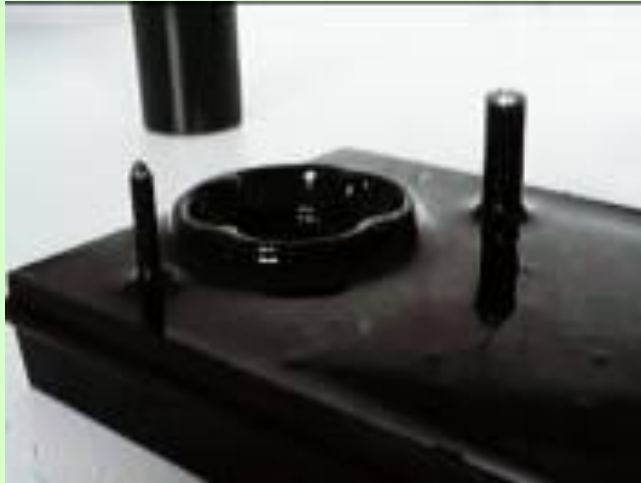

Conclusion

- Evaporative cooling is a must in floral greenhouse of Taiwan and S.E.A.
- Has the best performance in dry weather condition
- During the hot season of Taiwan, due to high humidity, at most 5 to 6 degree C drop is the limit
- Pad can be replaced by other materials such as multiple layers of nets